

Este es el producto que ha comprado!
This is the product you have purchased!
Esse é o produto que você adquiriu!
Voici le produit que vous avez acheté!

Ref. 1290

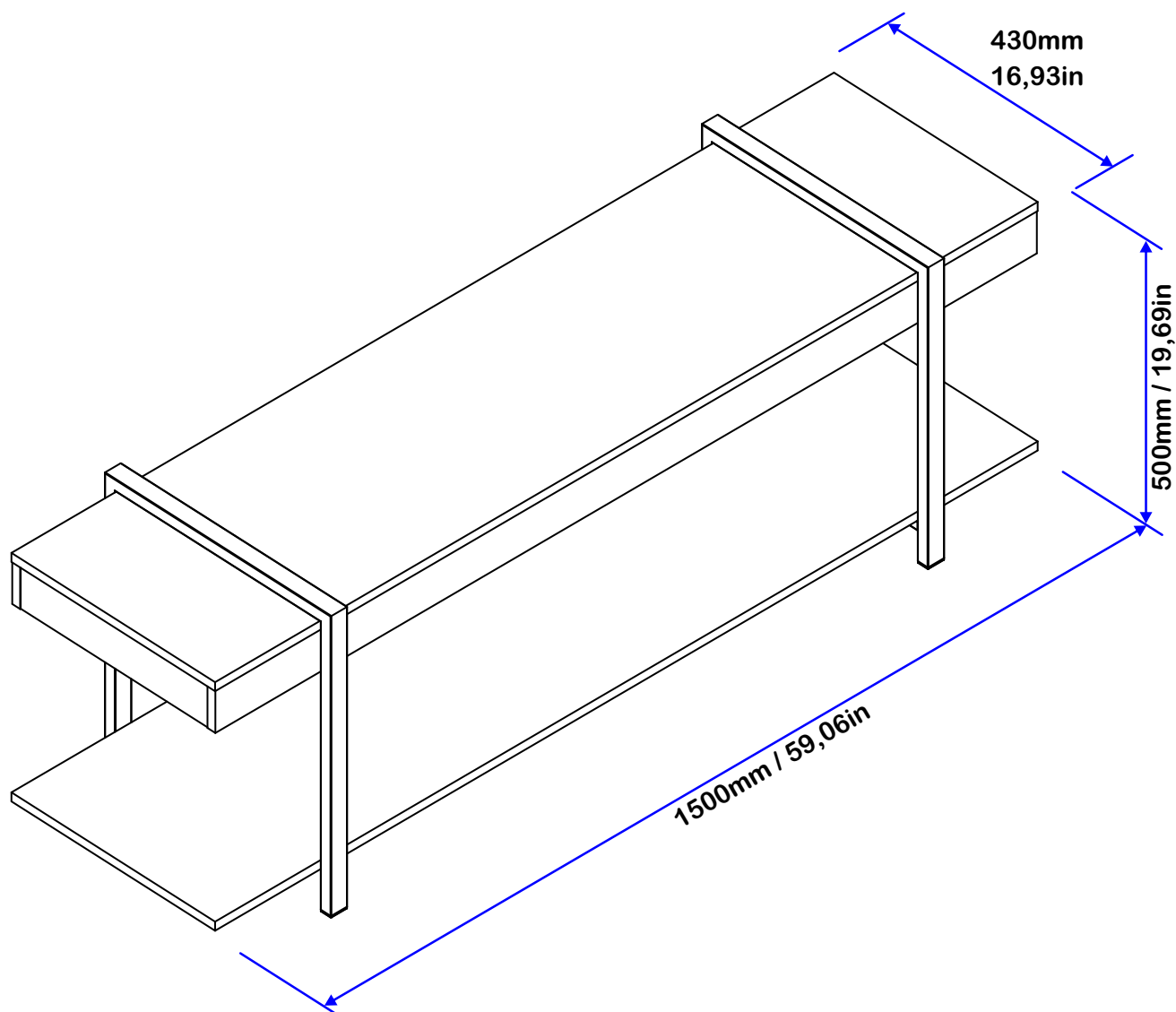

Consejos de Conservación y Pesos soportados

Conservation Tips and Supported Weights

Dicas de Conservação e Pesos Suportados

Conseils d'entretien et Poids soutenus

ES: 1. No debe utilizarse en la limpieza, abrasivos como lana de acero, alcohol, limón, o productos corrosivos que puedan rayar o quitar la película en los muebles.

2. Cuando la limpieza de muebles en general, napa y formica, deben utilizarse un paño ligeramente humedecido y jabón suave.
3. Para mover el mueble, es importante que este se eleve desde el suelo, debido a que el arrastre puede causar daño estructural.
4. No deje el mueble en exposición a la intemperie.

EN: 1. Do not use abrasive products to clean such as steel wool, alcohol, vinegar, lemon, scouring powder, or corrosive products which can scratch or peel off the protective film of the furniture.

2. The best way to clean your furniture is to use a slightly moistened cloth with a mild soap.
3. To move the furniture assembled, it is important that it is lifted off the ground, because the drag it can cause structural damage.
4. Do not leave your furniture in weather exposure.

PT: 1. Não utilizar na limpeza produtos abrasivos tais como: palha de aço, álcool, vinagre, limão, saponáceo ou produtos corrosivos que possam riscar ou descolar a película protetora dos móveis.

2. Na limpeza de móveis em geral, napas e fórmicas, deve ser utilizado um pano levemente umedecido e sabão neutro.
3. Para a movimentação do móvel, é importante que este seja levantado do chão, pois ao arrastá-lo pode causar avarias estruturais.
4. Não deixe o móvel em exposição a intempéries.

FR: 1. Ne pas utiliser de produits abrasifs dans le nettoyage, tels que: laine d'acier, alcool, vinaigre, citron, poudre à récurer ou autres produits corrosifs pouvant rayer ou faire décoller la pellicule protectrice des meubles.

2. Pour le nettoyage du meuble, il est recommandé d'utiliser un chiffon humide et du savon neutre.
3. Pour déplacer le meuble, il est important de le soulever du sol car le tirer pourrait causer des dommages dans sa structure.
4. Ne pas exposer le meuble aux intempéries.

ES: Por favor, preste atención a los pesos máximos admitidos por cada compartimento del producto. Tenga cuidado de no exceder estos pesos, con el fin de garantizar la calidad y durabilidad del producto. Es importante recordar que los pesos muestran en caso de ser DISTRIBUIDA en toda el área de la plataforma.

EN: Please pay attention to the maximum weights supported by each compartment product. Be careful not to exceed these weights, in order to ensure the quality and durability of the product. It is important to remember also that the weights shown should be DISTRIBUTED throughout the area of the shelf.

PT: Por favor, preste atenção aos pesos máximos suportados por cada compartimento do produto. Cuide para não exceder esses pesos, afim de garantir a qualidade e a durabilidade do mesmo. É importante lembrar também que, os pesos mostrados devem ser DISTRIBUÍDOS ao longo de toda a área da peça.

FR: Veuillez faire attention aux poids maximums supportés par chaque produit du compartiment. Veuillez à ne pas dépasser ces poids, afin de garantir la qualité et la durabilité du produit. Il est également important de se rappeler que les poids indiqués doivent être RÉPARTIS sur toute la surface du rayon.

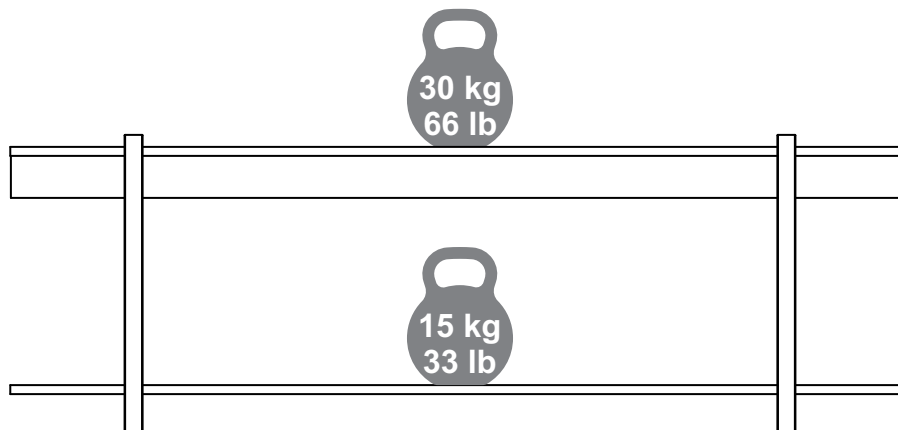



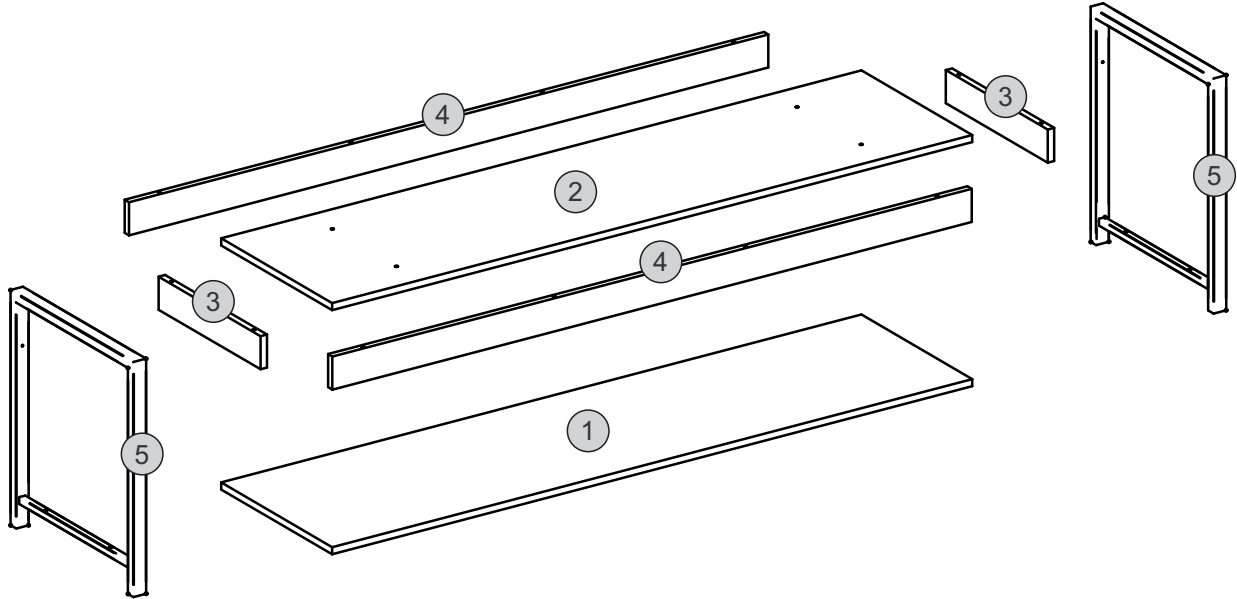



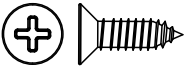
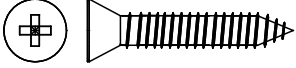

Conocer mejor las piezas de su producto 1
Getting to know your product parts better 1
Conhecendo melhor as peças do seu produto 1
Mieux connaître les pièces de votre produit 1

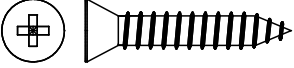

#	Ct. Qt.	Español	English	Português	Français	mm in
1	2	Base	Side	Lateral	Latérale	1499 x 387 x 15mm 59,02 x 15,24 x 0,59in
2	1	Tapa	Top	Tampo	Pièce du Dessus	1499 x 387 x 15mm 59,02 x 15,24 x 0,59in
3	1	Travesaño Lateral	Side Frame	Moldura Lateral	Travessa Côté	354 x 70 x 15mm 13,94x 2,76 x 0,59in
4	1	Travesaño Frontal y Trasero	Back and Front Frame	Moldura Frontal e Traseira	Travessa	1497 x 70 x 15mm 58,94 x 2,76 x 0,59in
5	1	Pata	Foot	Pé	Le Pied	497 x 430 x 20mm 19,57 x 16,93 x 0,79in

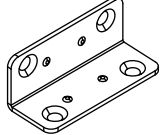
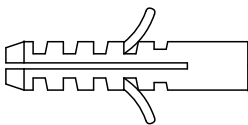
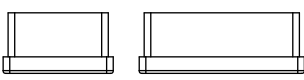
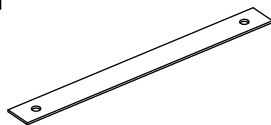
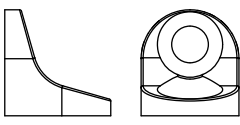
Y estos son sus Accesorios
And these are your Accessories
Estes são os seus Acessórios
ET voici vos Accessoires

<p>A</p>  <p>Ø4,2x13mm/0,16x0,51in (4x)</p>	<p>B</p>  <p>Ø4,2x25mm/0,17x0,98in (4x)</p>	<p>C</p>  <p>Ø3,5x12mm/0,14x0,47in (52x)</p>	<p>D</p>  <p>Ø4,0x25mm/0,16x0,98in (4x)</p>
<p>E</p>  <p>Ø3,5x30mm/0,14x1,18in (2x)</p>	<p>F</p>  <p>Ø4x50mm/0,16x1,97in (2x)</p>	<p>G</p>  <p>Ø6x30mm/0,24x1,18in (8x)</p>	<p>H</p>  <p>(12x)</p>
<p>I</p>  <p>Ø6mm/0,24in (2x)</p>	<p>J</p>  <p>(4x)</p>	<p>K</p>  <p>(2x)</p>	<p>L</p>  <p>(4x)</p>
<p>M</p>  <p>(4x)</p>			

Y si lo necesitas, mide en la regla al lado
And if you need to, measure on the ruler beside
E se precisar, meça na régua ao lado
ET si vous en avez besoin, mesurez sur la règle à côté

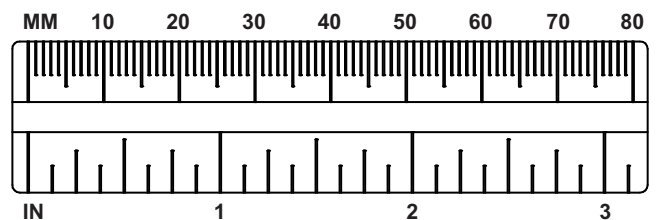

Y aquí, algunos Consejos de Montaje
And here, some Assembly Tips
Eaquí, algumas Dicas de Montagem
ET ici, quelques Conseils de Montage

HERRAMIENTAS NECESARIAS / TOOLS REQUIRED / FERRAMENTAS NECESSÁRIAS / OUTILS NÉCESSAIRES

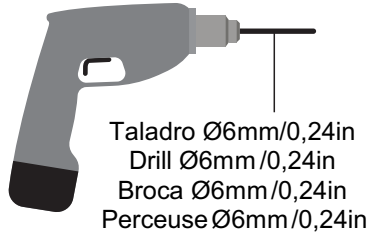
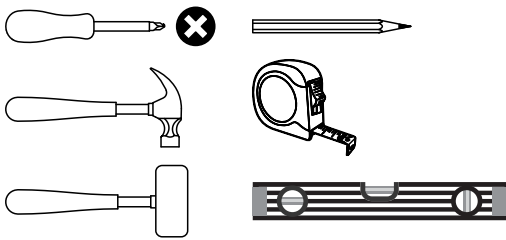

- NO UTILICE UN DESTORNILLADOR ELÉCTRICO O A BATERÍADO
- NOT USE A BATTERY OR ELECTRIC SCREWDRIVER
- NÃO UTILIZE PARAFUSADEIRA ELÉTRICA OU À BATERIA
- NE PAS UTILISER DE TOURNEVIS ÉLECTRIQUE OU À BATTERIE

NÚMERO DE PERSONAS Y ÁREA DE ARMADO
NUMBER OF PEOPLE AND ASSEMBLY AREA
NÚMERO DE PESSOAS E ÁREA DE MONTAGEM
NOMBRE DE PERSONNES ET ZONE DE RASSEMBLEMENT

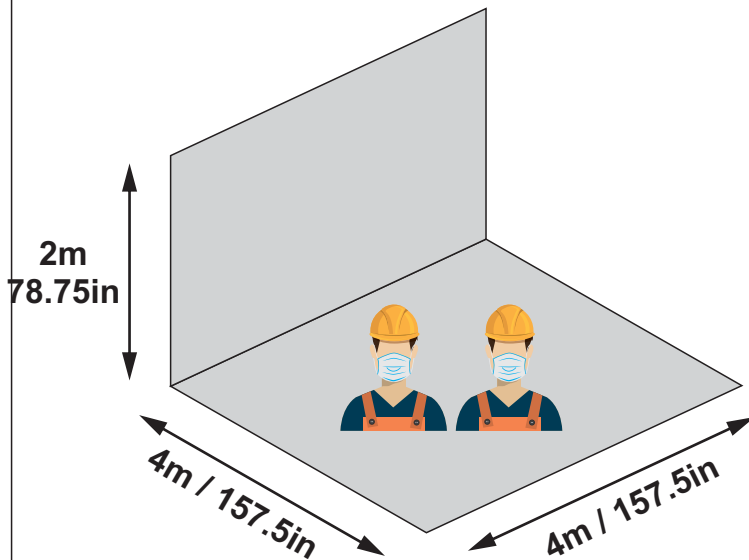

ÁREA GRIS / GRAY AREA / ÁREA CINZA / ZONE GRISE

ES: LAS ÁREAS MARCADAS CON COLOR GRIS SIGNIFICAN QUE ESTA PARTE DE LA PIEZA NO TIENE ACABADO, COMO LOS EJEMPLOS DE ABAJO.

EN: THE AREAS MARKED WITH THE COLOR GRAY MEAN THAT THIS PART OF THE PART IS NOT FINISHED, AS PER EXAMPLES BELOW.

PT: AS ÁREAS MARCADAS COM A COR CINZA SIGNIFICAM QUE ESSA PARTE DA PEÇA NÃO POSSUI ACABAMENTO, CONFORME EXEMPLOS ABAIXO.

FR: LES ZONES MARQUÉES D'UNE COULEUR GRISE SIGNIFIENT QUE CETTE PARTIE DE LA PIÈCE N'A PAS DE FINITION, COMME LES EXEMPLES CI-DESSOUS.

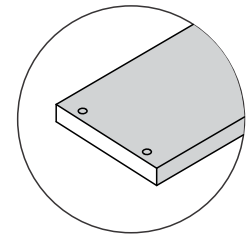
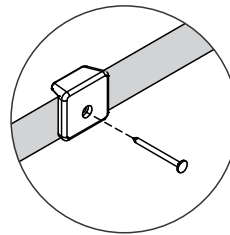

1

PIEZAS NECESARIAS
PARTS REQUIRED
PEÇAS NECESSÁRIAS
PIÈCES NÉCESSAIRES

3 x2 **4** x2

ACCESORIOS NECESARIOS
HARDWARE REQUIRED
ACESSÓRIOS NECESSÁRIOS
ACCESSOIRES NÉCESSAIRES

G  8
Ø6x30mm/0,24x1,18in

HERRAMIENTAS NECESARIAS
TOOLS REQUIRED
FERRAMENTAS NECESSÁRIAS
OUTILS NÉCESSAIRES

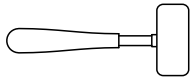

Detalle 1 / Detail 1
Detalhe 1 / Détail 1

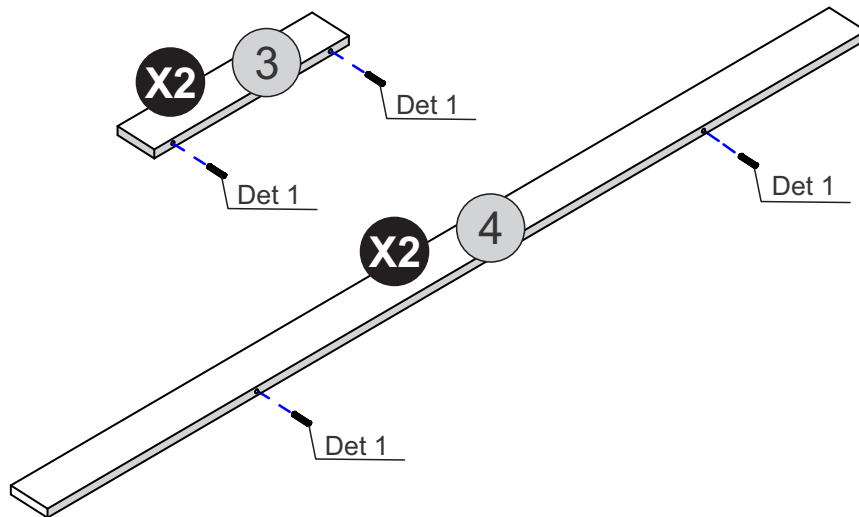
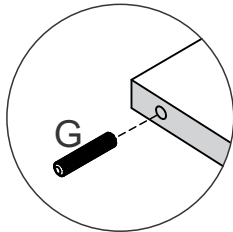

2

PIEZAS NECESARIAS
PARTS REQUIRED
PEÇAS NECESSÁRIAS
PIÈCES NÉCESSAIRES

2 x1 **4** x2

HERRAMIENTAS NECESARIAS
TOOLS REQUIRED
FERRAMENTAS NECESSÁRIAS
OUTILS NÉCESSAIRES

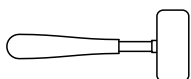

Detalle 2 / Detail 2
Detalhe 2 / Détail 2

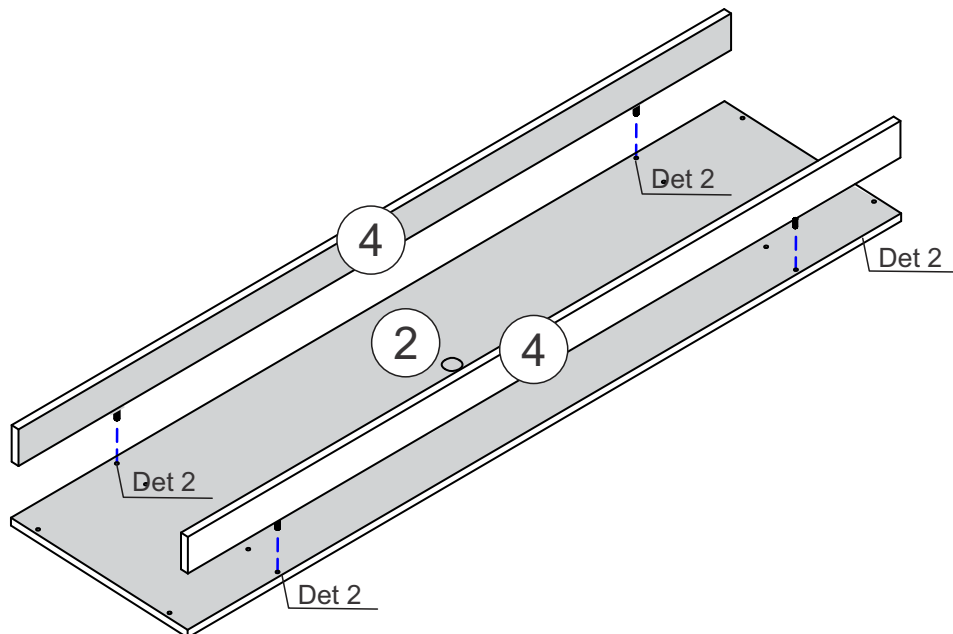
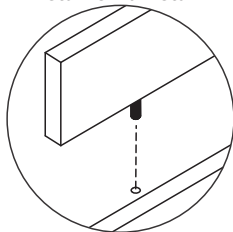

3

PIEZAS NECESARIAS
PARTS REQUIRED
PEÇAS NECESSÁRIAS
PIÈCES NÉCESSAIRES

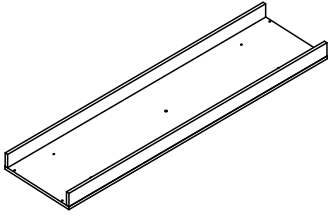

3 x2

HERRAMIENTAS NECESARIAS
TOOLS REQUIRED
FERRAMENTAS NECESSÁRIAS
OUTILS NÉCESSAIRES

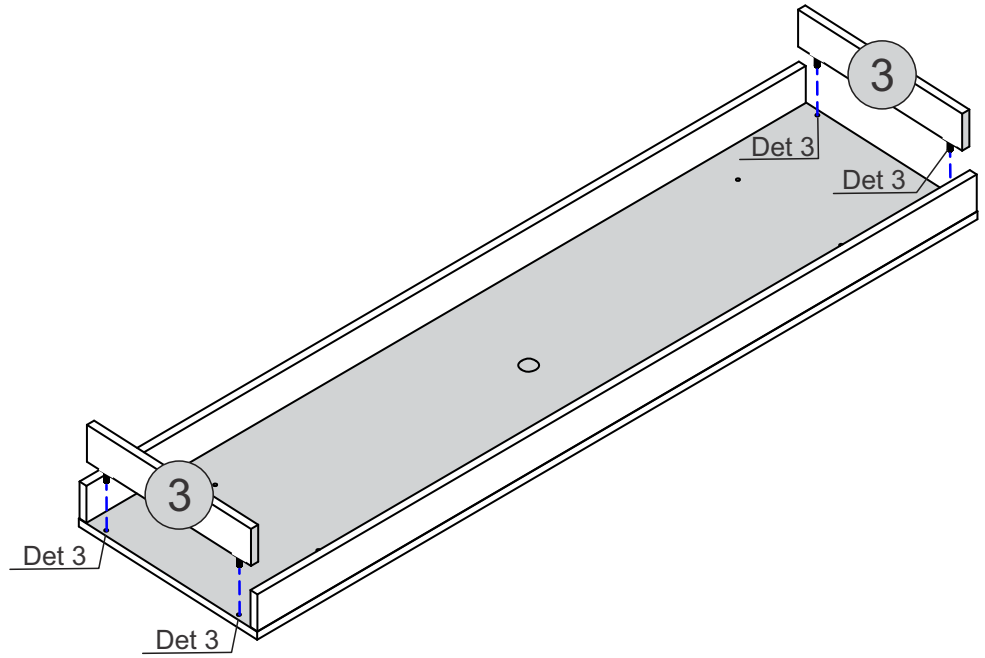
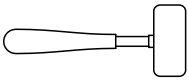

Detalle 3 / Detail 3
Detalhe 3 / Détail 3

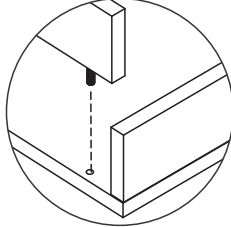

4

PIEZAS NECESARIAS
PARTS REQUIRED
PEÇAS NECESSÁRIAS
PIÈCES NÉCESSAIRES

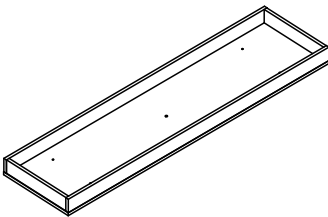

ACCESORIOS NECESARIOS
HARDWARE REQUIRED
ACESSÓRIOS NECESSÁRIOS
ACCESSOIRES NÉCESSAIRES

C  48
Ø3,5x14mm/0,14x0,55in

H  12

HERRAMIENTAS NECESARIAS
TOOLS REQUIRED
FERRAMENTAS NECESSÁRIAS
OUTILS NÉCESSAIRES

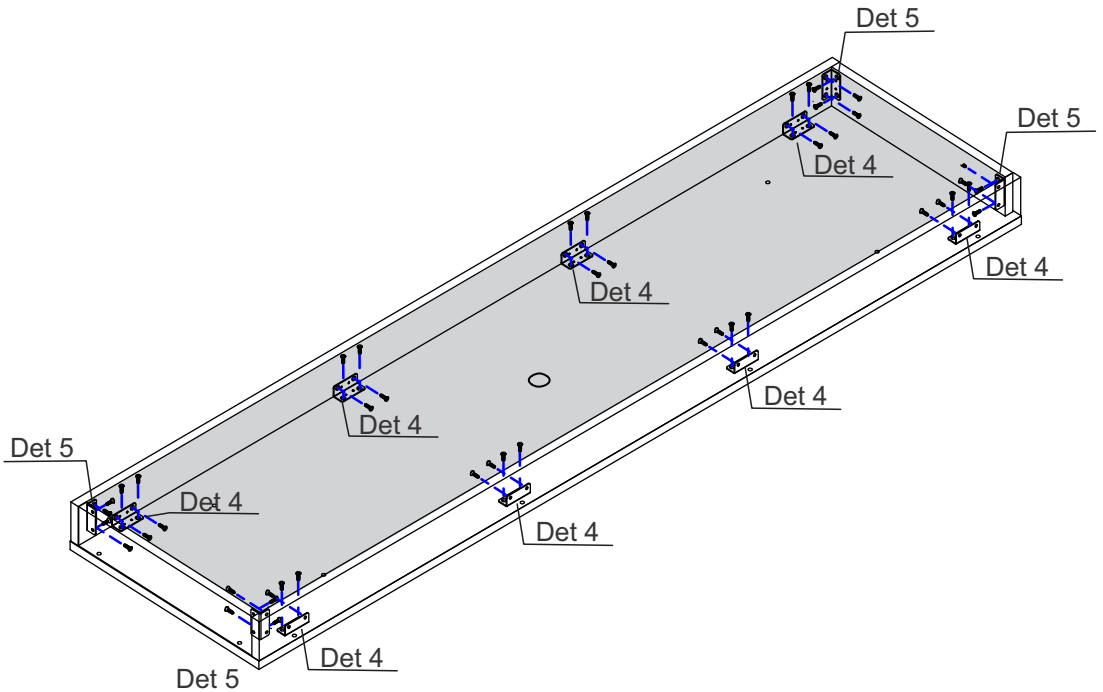
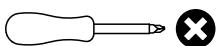

Detalle 4 / Detail 4
Detalhe 4 / Détail 4

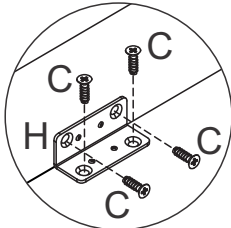

Detalle 5 / Detail 5
Detalhe 5 / Détail 5

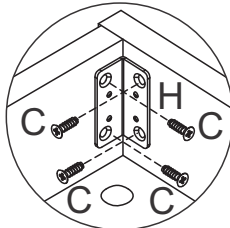

5

PIEZAS NECESARIAS
PARTS REQUIRED
PEÇAS NECESSÁRIAS
PIÈCES NÉCESSAIRES

5 x2

ACCESORIOS NECESARIOS
HARDWARE REQUIRED
ACESSÓRIOS NECESSÁRIOS
ACCESSOIRES NÉCESSAIRES

L  04

HERRAMIENTAS NECESARIAS
TOOLS REQUIRED
FERRAMENTAS NECESSÁRIAS
OUTILS NÉCESSAIRES

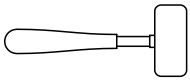

Detalle 6 / Detail 6
Detalhe 6 / Détail 6

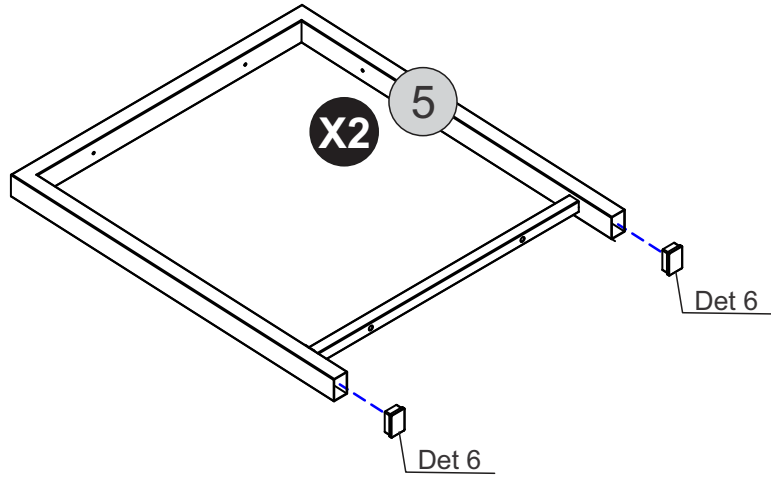
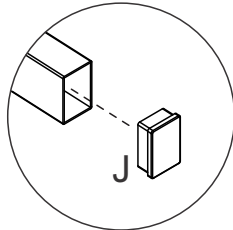

6

PIEZAS NECESARIAS
PARTS REQUIRED
PEÇAS NECESSÁRIAS
PIÈCES NÉCESSAIRES

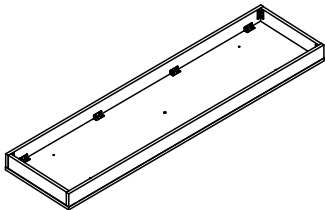

5 x2

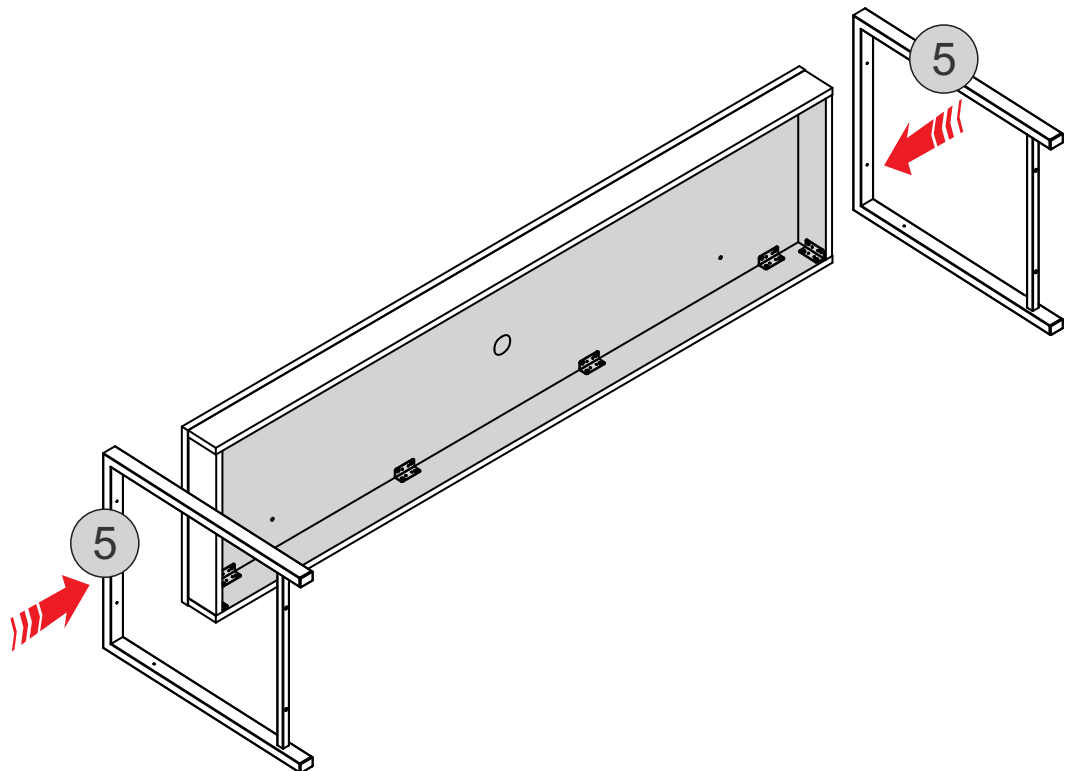

7

PIEZAS NECESARIAS
PARTS REQUIRED
PEÇAS NECESSÁRIAS
PIÈCES NÉCESSAIRES

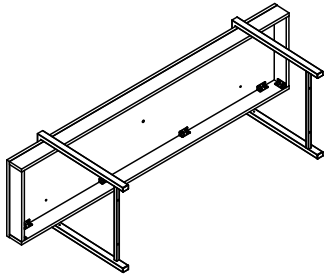

ACCESORIOS NECESARIOS
HARDWARE REQUIRED
ACESSÓRIOS NECESSÁRIOS
ACCESSOIRES NÉCESSAIRES

B  04
Ø4,2x25mm/0,17x0,98in

HERRAMIENTAS NECESARIAS
TOOLS REQUIRED
FERRAMENTAS NECESSÁRIAS
OUTILS NÉCESSAIRES

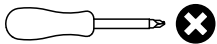

Detalle 7 / Detail 7
Detalhe 7 / Détail 7

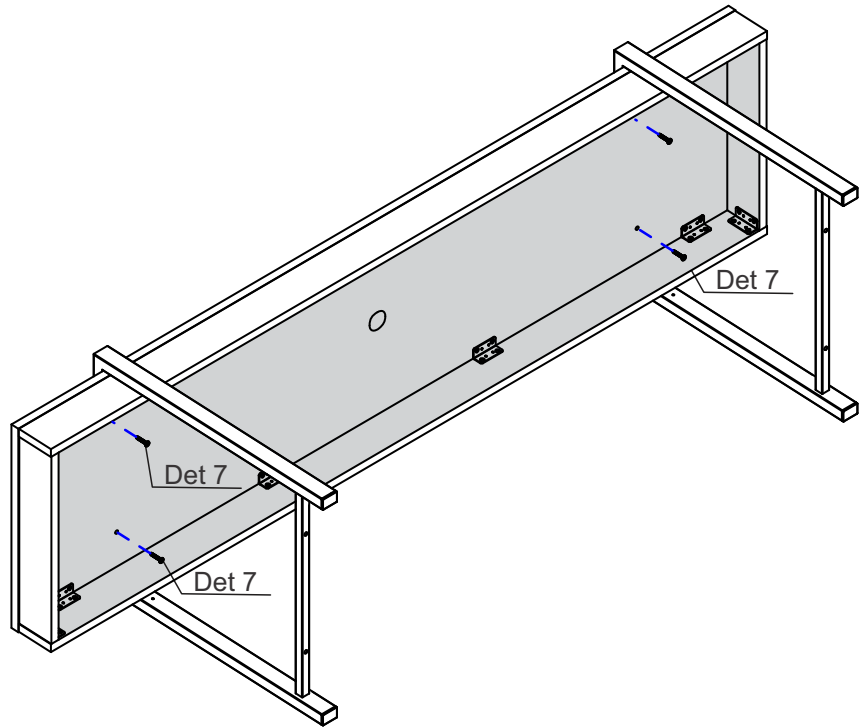
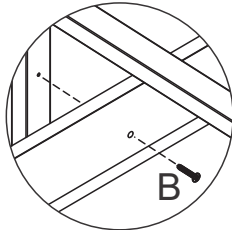

8

PIEZAS NECESARIAS
PARTS REQUIRED
PEÇAS NECESSÁRIAS
PIÈCES NÉCESSAIRES

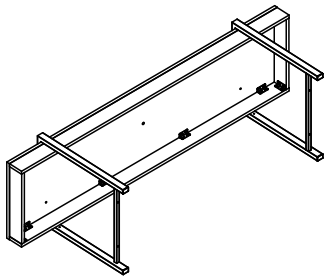

ACCESORIOS NECESARIOS
HARDWARE REQUIRED
ACESSÓRIOS NECESSÁRIOS
ACCESSOIRES NÉCESSAIRES

A  04
Ø4,2x13mm/0,16x0,51in

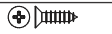
C  04
Ø3,5x12mm/0,14x0,47in

L  04

HERRAMIENTAS NECESARIAS
TOOLS REQUIRED
FERRAMENTAS NECESSÁRIAS
OUTILS NÉCESSAIRES

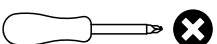

Detalle 8 / Detail 8
Detalhe 8 / Détail 8

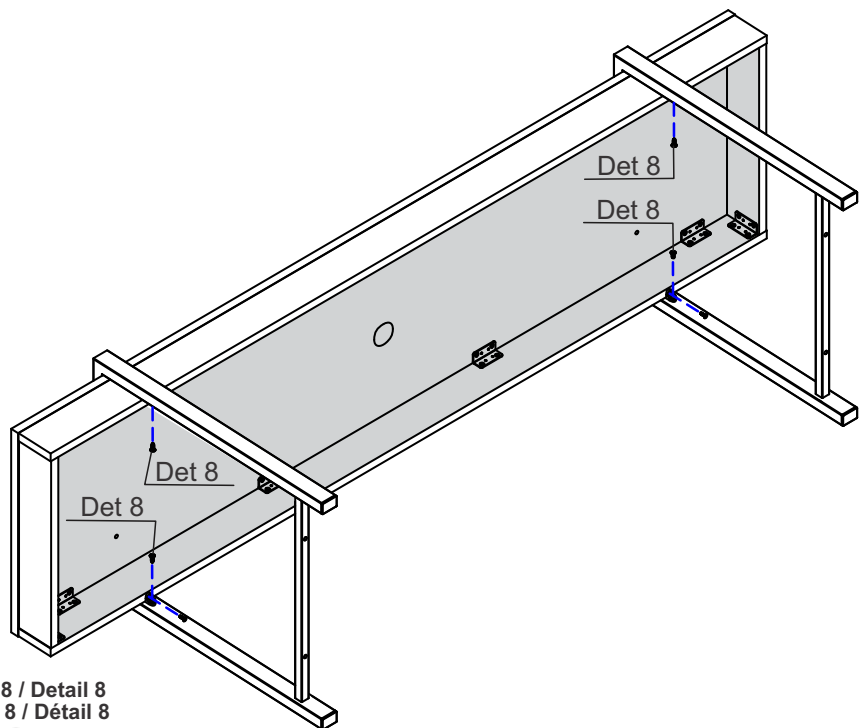
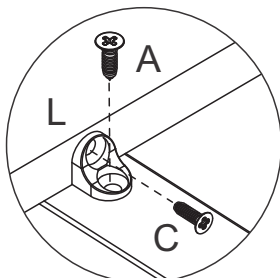

9

PIEZAS NECESARIAS
PARTS REQUIRED
PEÇAS NECESSÁRIAS
PIÈCES NÉCESSAIRES

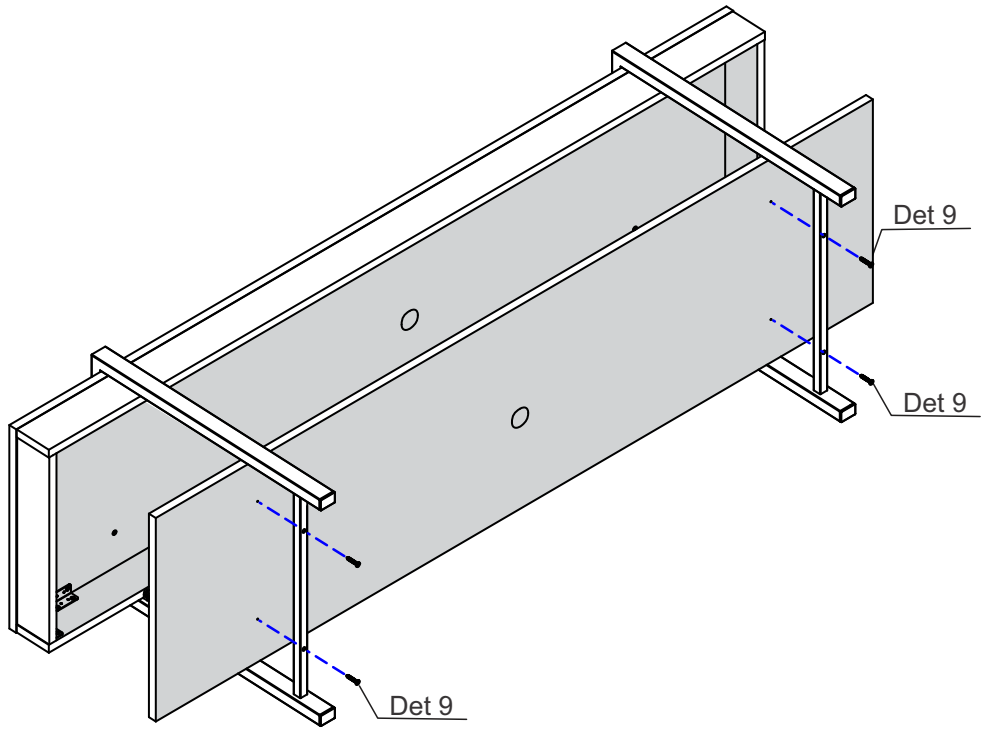
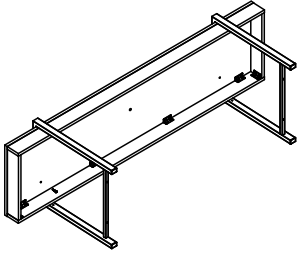

1 x1

ACCESORIOS NECESARIOS
HARDWARE REQUIRED
ACESSÓRIOS NECESSÁRIOS
ACCESSOIRES NÉCESSAIRES

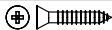
D  04
Ø4x25mm/0,16x0,98in

HERRAMIENTAS NECESARIAS
TOOLS REQUIRED
FERRAMENTAS NECESSÁRIAS
OUTILS NÉCESSAIRES

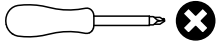

Detalle 9 / Detail 9
Detalhe 9 / Détail 9

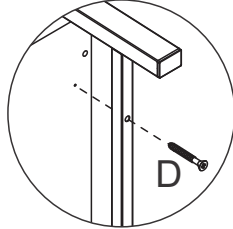

10

PIEZAS NECESARIAS
PARTS REQUIRED
PEÇAS NECESSÁRIAS
PIÈCES NÉCESSAIRES

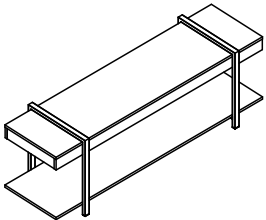

ACCESORIOS NECESARIOS
HARDWARE REQUIRED
ACESSÓRIOS NECESSÁRIOS
ACCESSOIRES NÉCESSAIRES

E  02
Ø3,5x30mm/0,14x1,18in

M  02

N  02

HERRAMIENTAS NECESARIAS
TOOLS REQUIRED
FERRAMENTAS NECESSÁRIAS
OUTILS NÉCESSAIRES

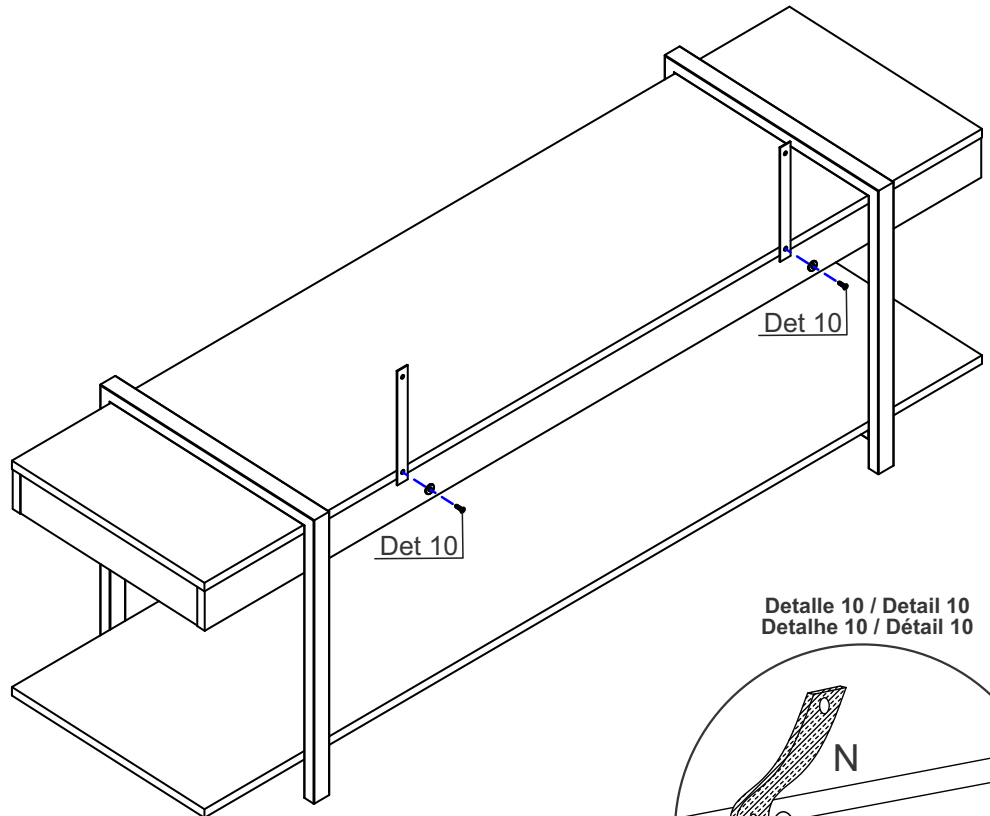
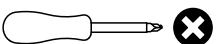

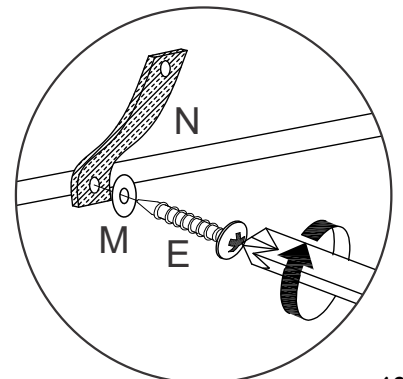

Detalle 10 / Detail 10
Detalhe 10 / Détail 10

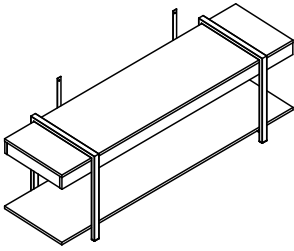

PIEZAS NECESARIAS
PARTS REQUIRED
PEÇAS NECESSÁRIAS
PIÈCES NÉCESSAIRES



ACCESORIOS NECESARIOS
HARDWARE REQUIRED
ACESSÓRIOS NECESSÁRIOS
ACCESSOIRES NÉCESSAIRES

F	 Ø4x50mm/0,16x1,97in	02
I	 Ø6mm/0,24in	02
M		02

HERRAMIENTAS NECESARIAS
TOOLS REQUIRED
FERRAMENTAS NECESSÁRIAS
OUTILS NÉCESSAIRES

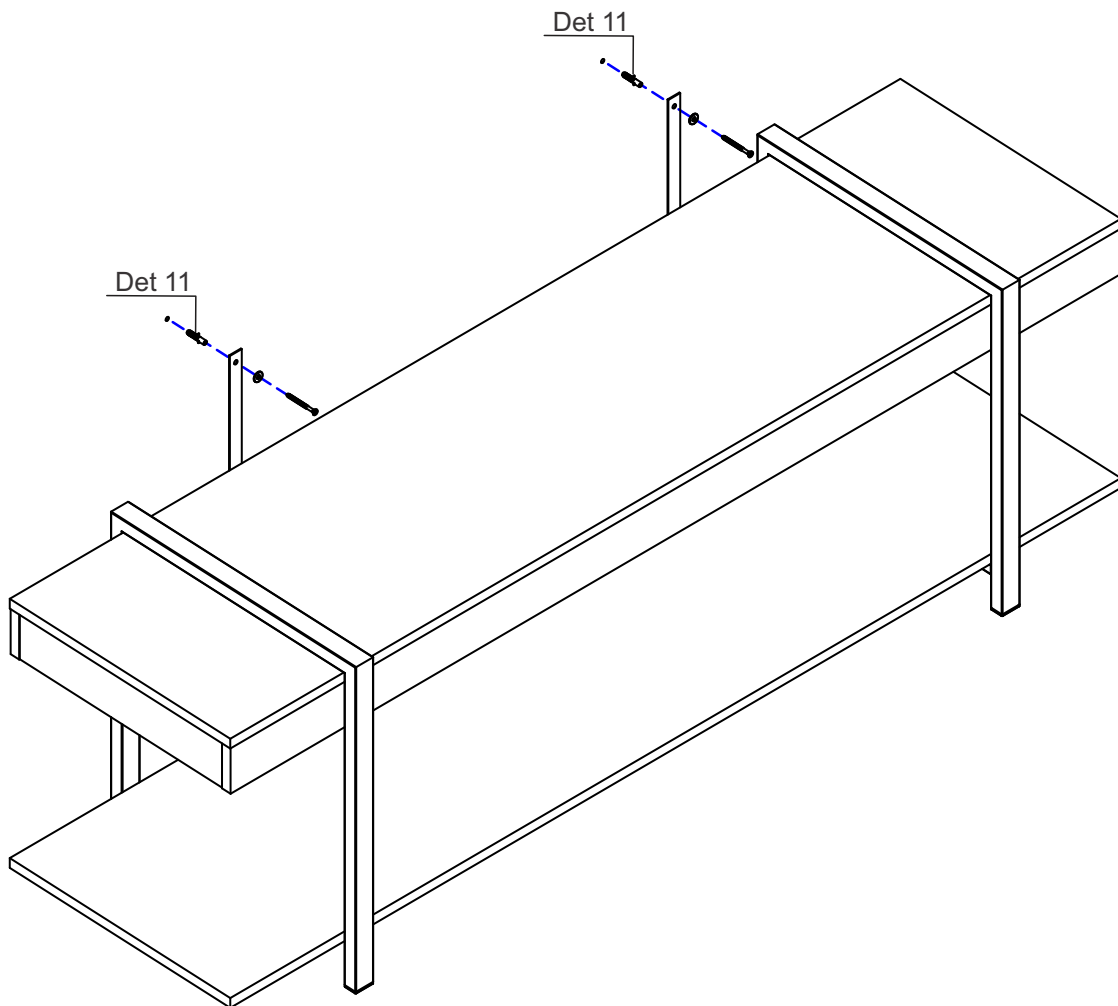
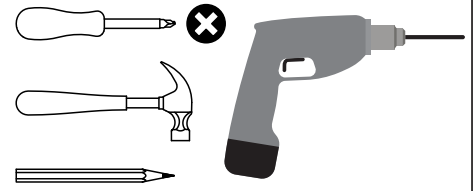

Detalle 11 / Detail 11
Detalhe 11 / Détail 11



ES: CONSEJOS DE MONTAJE EN LA PARED EN LA ÚLTIMA PÁGINA
EN: WALL MOUNTING TIPS ON THE LAST PAGE
PT: DICAS DE FIXAÇÃO NA PAREDE NA ÚLTIMA PÁGINA
FR: CONSEILS DE MONTAGE MURAL À LA DERNIÈRE PAGE

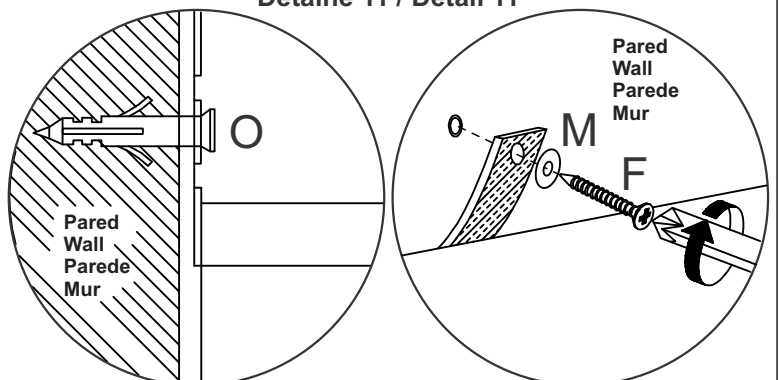

Guía de Montaje/Fijación a la pared - Mounting Guide/Wall Fixings - Guia de Montagem/Fixações na Parede



1. Al taladrar en las paredes, compruebe siempre que no haya cables, tuberías ocultos, etc.
1. When drilling into walls always check that there are no hidden wires, pipes, etc.
1. Atenção: Na furação em paredes, sempre verifique se não existem fios, tubos escondidos, etc.
2. Asegúrese de que los tornillos y bujes de la pared utilizados sean adecuados para soportar su producto. En caso de duda, consulte a un profesional cualificado.
2. Make sure that the screws and wall plugs being used are suitable for supporting your product. Consult a qualified professional if you are unsure.
2. Certifique-se de que os parafusos e buchas utilizados são adequados para suportar o seu produto. Em caso de dúvida, consulte um profissional qualificado.



1. Asegúrese de usar el taladro correcto para que coincida con el buje de la pared y el tamaño del taladro.
1. Ensure to use the recommended drill bit to match the wall plug and hole size.
1. Certifique-se de utilizar a broca correta para combinar com a bucha de parede e o tamanho da furação.
2. Asegúrese de taladrar el agujero horizontalmente, no fuerce la taladradora ni agrande el agujero.
2. Ensure to drill the hole horizontally, do not force the drill or enlarge the hole.
2. Certifique-se de fazer o furo na horizontal, não force ou aumente o diámetro do furo.
3. Asegúrese de que los bujes de la pared estén bien asentados y apretados en los orificios.
3. Ensure wall plugs are well fitted and are a tight fit in the drilled hole.
3. Certifique-se de que as buchas de parede estão bem encaixadas e apertadas nas furações.



Buje Plastica 6mm (suministradas) / 6mm Plastic Wall Plug (supplied) / Bucha Plástica 6mm (fornecidas)

1. Estos bujes de pared de plástico sólo son adecuados para su uso en paredes de mampostería.
1. These types of wall plugs are only suitable for use in masonry walls.
1. Estas buchas plásticas de parede são adequadas somente para uso em paredes de alvenaria.
2. La falla del producto debido al uso de fijaciones incorrectas es responsabilidad del instalador.
2. Failure of the product due to using incorrect fixings is the responsibility of the installer.
2. A falha do produto devido à utilização de fixações incorretas é de responsabilidade do instalador.

Tipos de Pared y Fijaciones / Wall Types and Fixings / Tipos de Parede e Fixações

* En la siguiente tabla se muestran ejemplos de modelos de bujes de pared y su aplicación según el material de la pared. ATENCIÓN, ya que todas las cargas soportadas son válidas siempre que la instalación cumpla con las especificaciones ideales. En caso de duda, consulte a un profesional cualificado para la correcta instalación.

* In the table below, examples of models of wall plugs and their application according to the material of the wall. ATTENTION, as all supported loads are valid as long as the installation complies with the ideal specifications. In case of doubt, consult a qualified professional for the correct installation.

* Na tabela abaixo, exemplos de modelos de buchas de parede e sua aplicação conforme o material da parede. ATENÇÃO, pois todas as cargas suportadas são válidas desde que a instalação respeite as indicações ideais. Em caso de dúvidas, consulte um profissional qualificado para a correta instalação.

Modelos de Bujes de Pared / Modelos de Buchas / Models of Wall Plugs

Tipos de Pared Wall Types Tipos de Parede											
Hormigón Concrete Concreto	✓	✓	✓								✓
Bloque de Hormigón Concrete Block Bloco de Concreto	✓	✓	✓	✓	✓						
Ladrillo Huevo Hollow Brick Tijolo Oco		✓	✓	✓	✓						
Ladrillo Macizo Solid Brick Tijolo Maciço	✓	✓	✓								✓
Paneles de yeso (Drywall) Drywall Painel de Drywall			✓		✓	✓	✓	✓	✓	✓	